

Operation Manual of Solar Controller SolCon-002 for Split Solar System

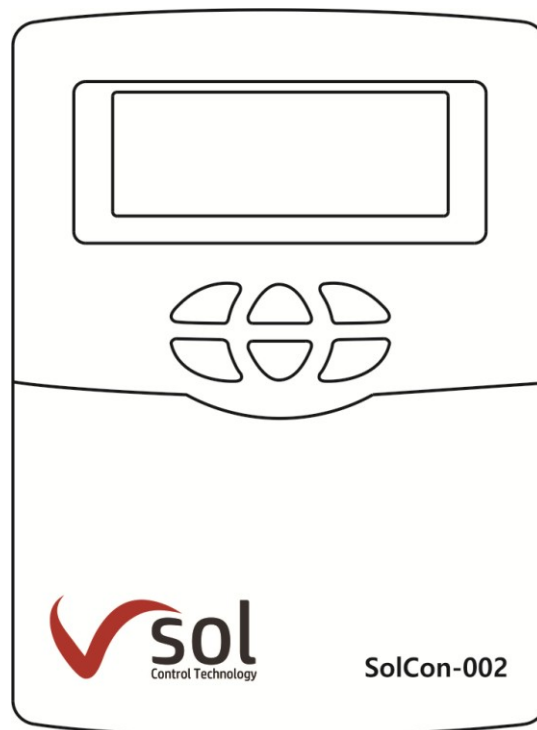

 Read the instruction carefully please before operation!

Contents

1. Safety information	3
1.1 Installation and commissioning	3
1.2 About this manual	3
1.3 Liability waiver	3
1.4 Important information	4
1.5 Signal description	4
1.6 Button and HMI description	4
2. Overview	5
2.1 Technical data	5
2.2 Delivery list	6
3. Installation	6
3.1 Mounting controller	6
3.2 Wiring connection	7
3.3 Terminal connection	7
3.3.1 Electrical heating 1500W version terminal ports and wiring	7
3.3.1 Electrical heating 3000W version terminal ports and wiring	8
3.4 Connection with high efficiency pump	10
4. System description (Standard solar system with 1 tank, 1 collector field)	11
5. Function's parameters and options	12
5.1 Overview of menu structure	12
5.2 Menu operation description	13
5.3 Value checking	13
6. Functions operation and parameters setting (for user)	14
6.1 CLK Time setup	14
6.2 THET Timing heating	14
6.3 CIRC DHW circuit pump controlled by temperature in three time - sections / flow switcher	17
7. Function operation and parameter setup (engineer)	22
7.1 PWD Password	22
7.2 LOAD tank heating	23
7.3 COL Collector function	26
7.4 PUMP Pump R1 control mode	31

7.5 COOL Cooling function	33
7.6 AUX Auxiliary function	37
7.7 MAN Manual operation	42
7.8 BLPR Blocking protection	42
7.9 OTDI Thermal Disinfection function	43
7.10 OHQM Thermal quantity measurement	45
7.11 FS Flow meter selection and flow rate monitoring	47
7.12 UNIT C-F Switch	48
7.13 RET Reset.....	49
7.14 PASS Password setup	50
7.15 M.H Manual heating	50
7.16 Holiday function.....	51
7.17 Economic model.....	52
7.18Shortcut key function.....	52
8. Protection function.....	52
8.1 Memory function during power failure.....	52
8.2 Screen protection	52
8.3 Trouble checking	52
9. Quality Guarantee	53
10. Accessories	54

1. Safety information

1.1 Installation and commissioning

- When laying wires, please ensure that no damage occurs to any of the constructional fire safety measures presented in the building.
- The controller must not be installed in rooms where easily inflammable gas mixtures are present or may occur.
- The permissible environmental conditions can't be exceeded at the site of installation.
- Before connecting the device, make sure that the energy supply matches the specifications that the controller requires.
- All devices connected to the controller must be conformed to the technical specifications of the controller.
- All operations on an open controller are only to be conducted cleared from the power supply. All safety regulations for working on the power supply are valid.
- Connecting and /or all operations that require opening the collector (e.g. changing the fuse) are only conducted by specialists.

1.2 About this manual

This manual describes the mounting, functions and operation of a solar controller used for a solar hot water system, for mounting of other devices of a completed solar hot water system like solar collector, pump station and storage, please is sure to observe the appropriate installation instructions provided by each manufacturer. Mounting, wire connecting, commissioning and maintenance of this controller may only be performed by the trained professional person; the professional person should be familiar with this manual and follow the instructions contained herein.

1.3 Liability waiver

The manufacturer can't monitor the compliance with these instructions or the circumstances and methods used for installation, operation, utilization and maintenance of this controller. Improper installation can cause damages to material and person. This is the reason why we do not take over the responsibility and liability for losses, damages or cost that might arise due to improper installation, operation or wrong utilization and maintenance or that occurs in some connection with the aforementioned. Moreover we do not take over liability for patent infringements or infringements – occurring in connection with the use of this controller on the third parties rights. The manufacturer preserves the right to put changes to product, technical data or installation and operation instructions without prior notice. As soon as it becomes

evident that safe operation is no longer possible (e.g. visible damage). Please immediately take the device out of operation. Note: ensure that the device can't be accidentally placed into operation.

1.4 Important information

We have carefully checked the text and pictures of this manual and provided the best of our knowledge and ideas, however inevitable errors may exist. Please note that we cannot guarantee that this manual is given in the integrity of image and text, incorrect, incomplete and erroneous information and the resulting damage we do not take responsibility.

1.5 Signal description



Safety indication: Safety indications in the text are marked with a warning triangle.

They indicate measures which can lead to injury of person or safety risks.



Operation steps: small triangle "►" is used to indicate operation step.



Note: Contains important information about operation or functions.













1.6 Button and HMI description



➤ Controller is operated with the 6 buttons on the right side of the screen

- "  " holiday button
- "M.H" button: manual heating
- "SET" button: confirm / selection
- "▲" up button: increase the value
- "▼" down button: reduce the value
- "ESC" button return/ exit : return to previous menu

Operation manual of solar controller SolCon-002

Status description	Code	Lighting	Blinking
Exceed the maximum temperature of storage	SMX		
Running of storage emergency shutdown function			
Running of collector emergency shutdown function	CEM		 + 
Collector Cooling	OCCO		
Tank Cooling	OSTC		
System Cooling	OSYC		
Start of anti-freezing function	OCFR		
Running of anti-freezing function	OCFR		
Collector minimum temperature	OCMI		 Slow blink
No flow alarm	L/M 0.0		 

2.Overview

2.1 Technical data

- **Inputs:** 1 * PT1000 temperature sensor input
4 * NTC10K, B=3950 temperature sensor input
1 * FRT rotary vane type electronic flow meter
- **Outputs:** 2* Electromagnetic relay(R2/R3), maximum current 1A
1* Semiconductor relay(R1), maximum current 1A
1* Electromagnetic relay(HR), maximum current 10A/15A
1 * PWM variable frequency output (on/off switchable, 0-10V)
- **Functions:** operating hours counter, tube collector function, thermostat function, pump speed control, external heat exchange, adjustable system parameters and optional functions (menu-driven), balance and diagnostics
- **Power supply:** 100...240V ~(50...60Hz)
- **Rated impulse voltage:** 2.5KV
- **Housing:** Plastic ABS
- **Mounting:** Wall mounting
- **Operation:** 6 push buttons at the front cover
- **Protection type:** IP41
- **Ambient temperature:** 0...40 °C
- **Dimensions:** 187*128*46mm

i **Note:** there are 4 inputs for NTC10K, B=3950 temperature sensor, but only 2 sensors are included in standard delivery list, the other two should be purchased separately by customer if necessary.

2.2 Delivery list

SolCon-002 1500W version Delivery list	SolCon-002 3000W version Delivery list
● 1 * SolCon-002 controller	● 1 * SolCon-002 controller
● 1 * Accessory bag	● 1 * Accessory bag
● 1 * User manual	● 1 * User manual
● 1 * PT1000 temperature sensor (φ6*50mm,cable length 1.5meter)	● 1 * PT1000 temperature sensor (φ6*50mm,cable length 1.5meter)
● 2 * NTC10K temperature sensor (φ6*50mm,cable length 3meter)	● 2 * NTC10K temperature sensor (φ6*50mm,cable length 3meter)
● 1* Power cord	● No power cord delivery (please prepare 2.5mm ² wiring directly)

3. Installation



Note:The unit must only be located in the dry interior rooms. Please separate routing of sensor wires and mains wires. Make sure the controller as well as the system is not exposed to strong electromagnetic fields.

3.1 Mounting controller

Follow the below steps to mount the controller on the wall.

- Unscrew the crosshead screw from the cover and remove it along with the cover from the housing.
- Mark the upper fastening point ① on the wall. Drill and fasten the enclosed wall plug and screw leaving the head protruding.
- Hang the housing from the upper fastening point and mark the lower fastening points ②.
- Drill and insert lower wall plugs.

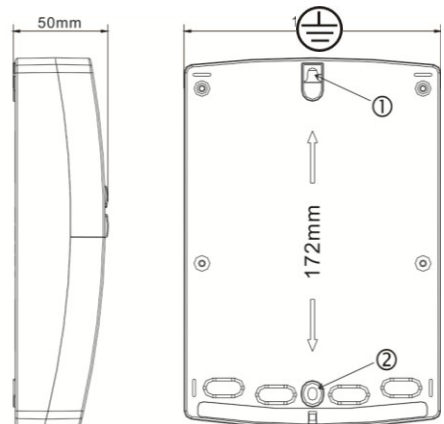

- Fasten the housing to the wall with the lower fastening screw and tighten.
- Carry out the electrical wiring in accordance with the terminal allocation
- Put the cover on the housing. Attach with the fastening screw.

3.2 Wiring connection

According to the way of installation, wire can be connected from hole A on the bottom plate or from hole B, using a suitable tool (like knife) to cut the plastic of A.

i **Note:** wires must be fastened by fixing clamps on the position C.

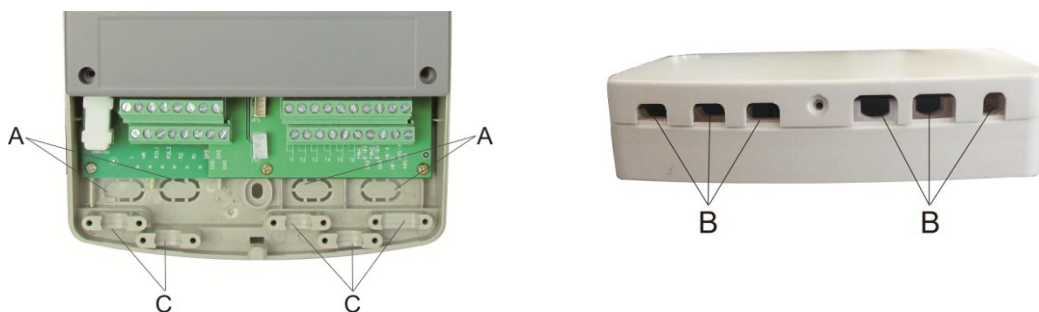

3.3 Terminal connection

3.3.1 Electrical heating 1500W version terminal ports and wiring



Note: before opening the housing! Always disconnect the controller from power supply and obey the local electrical supply regulation.

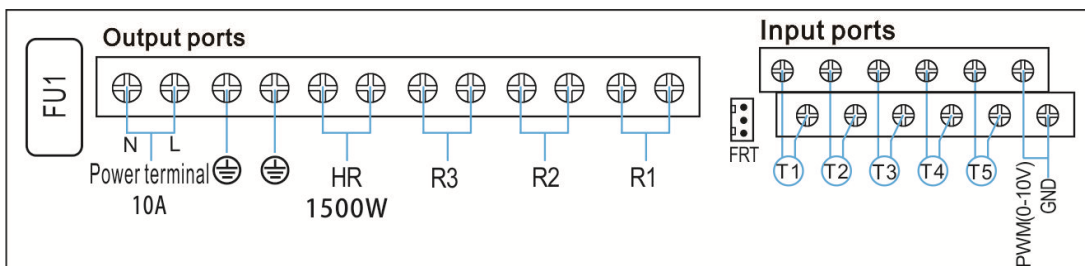

● Input ports

- T1: PT1000 temperature sensor, for measuring the temperature of collector and thermal energy calculation.
- T2 ~T5: NTC10K, B=3950 temperature sensor, for measuring temperature of tank and pipe.
- PWM: Signal ports for high efficiency pump, detailed connection see below

- FRT: For rotary vane type electronic flowmeter.

- **Output ports**

- FU1: 2A/250V fuse
- 10A power supply Ports L, N: for power connection, L: live wire, N: zero wire,  protective wire
- Output R1: Semiconductor relays (SCR), designed for pump speed control, Max. Current: 1A
- Output R2: Electromagnetic relays, designed for on/off control of pump or 3-ways electromagnetic valve, Max. Current: 1A
- Output R3: Electromagnetic relays, designed for on/off control of pump or 3-ways electromagnetic valve, Max. Current: 1A
- Output (1500W) HR: Electromagnetic relays, designed for on/off control of after heating/thermostat function, Max. Current: 10A

1).When power supply AC230V output HR is 1500W.

2).When power supply AC110V output HR is 750W.

3.3.1 Electrical heating 3000W version terminal ports and wiring

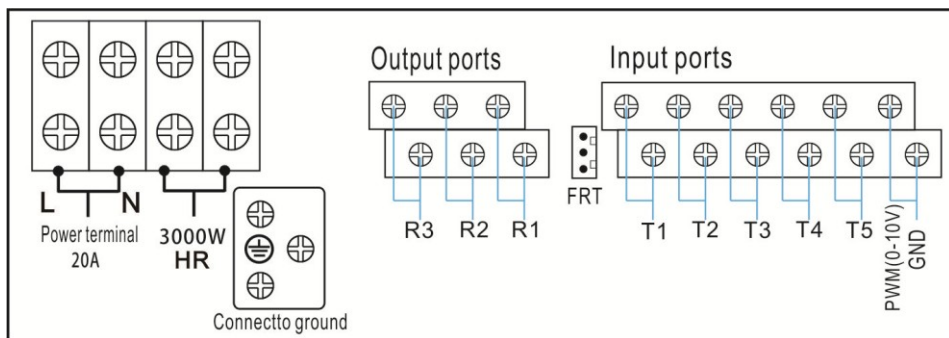

- **Input ports**

- T1: PT1000 temperature sensor, for measuring the temperature of collector and thermal energy calculation.
- T2 ~T5: NTC10K, B=3950 temperature sensor, for measuring temperature of tank and pipe.
- PWM: Signal ports for high efficiency pump, detailed connection see below
- FRT: For rotary vane type electronic flowmeter

● **Output ports**

- 15A power supply Ports L, N: for power connection, L: live wire, N: zero wire,  protective wire
- Output R1: Semiconductor relays (SCR), designed for pump speed control, Max. Current: 1A
- Output R2: Electromagnetic relays, designed for on/off control of pump or 3-ways electromagnetic valve, Max. Current: 1A
- Output R3: Electromagnetic relays, designed for on/off control of pump or 3-ways electromagnetic valve, Max. Current: 1A
- Output (3000W) HR: Electromagnetic relays, designed for on/off control of after heating/thermostat function, Max. Current: 15A

1).When power supply AC230V output HR is 3000W.

2).When power supply AC110V output HR is 1500W.

● **Advice regarding the installation of temperature sensors:**

- Only original factory equipped Pt1000 temperature sensors are approved for using with the controller, it is equipped with 1.5m silicon cable and suitable for all weather conditions, the cable is temperature resistant up to 280°C, connect the temperature sensors to the corresponding terminals with either polarity.
- Only original factory equipped NTC10K,B=3950 temperature sensors are approved for using with tank and pipe, it is equipped with 3m PVC cable, and the cable is temperature resistant up to 105°C, connect the temperature sensors to the corresponding terminals with either polarity.
- All sensor cables carry low voltage, and to avoid inductive effects, must not be laid close to 230 volt or 400 volt cables (minimum separation of 100mm).
- If external inductive effects are existed, e.g. from heavy current cables, overhead train cables, transformer substations, radio and television devices, amateur radio stations, microwave devices etc., then the cables to the sensors must be adequately shielded.
- Sensor cables may be extended to a maximum length of ca. 100 meter, when cable's length is up to 50m, and then 0.75mm² cable should be used. When cable's length is up to 100m, and then 1.5mm² cables should be used.

3.4 Connection with high efficiency pump

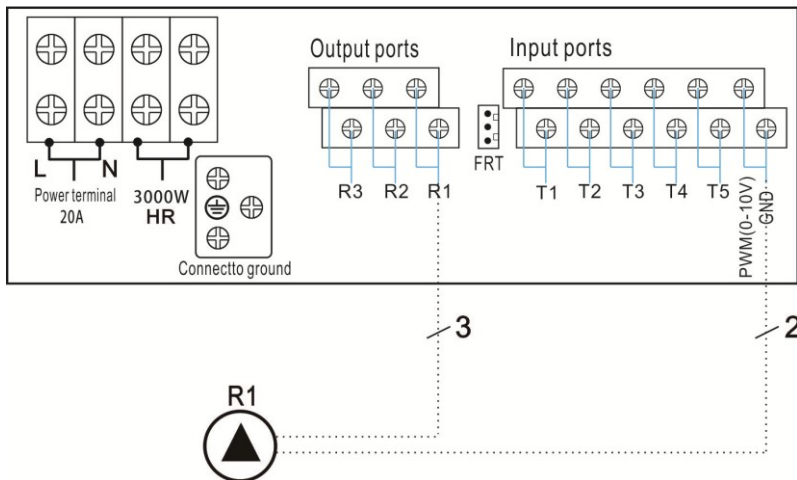

Connecting the signal wire from the high-efficiency pump

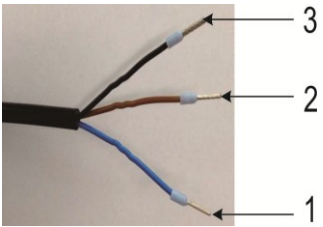

Signal	Overmoulded Pin	Cable color
PWM input (from controller)	1	Grey or blue
PWM common	2	brown
PWM output (from the pump)	3	black

Signal wire 1 from the high-efficiency pump is connected to GND port of controller

Signal wire 2 from the high-efficiency pump is connected to PWM port of controller

Signal wire 3 from the high-efficiency pump is not connected to the controller

Some pumps connections are available as above, for example:

WiloYonos PARA ST15/7.0 PWM2 M

Grundfos UPM3 SOLAR 15-75 130 CZA

i **Note:**

1. High-efficiency pump with 0-10V signal only has 2 signal wires, connected to the corresponding port GND, PWM1 of controller.
2. Blue wire not always represent for "GND" and brown wire not always represent for "PWM".
 "PWM" from pump must be match for "PWM" from controller.
 "GND" from pump must be match for "GND" from controller.

4. System description (Standard solar system with 1 tank, 1 collector field)

Description:

The controller calculates the temperature difference between collector sensor T1 and tank sensor T2. If the difference is larger than or identical to the adjusted switch-on temperature difference, the solar circulation pump (R1) will be switched on and the tank will be loaded until the switch-off temperature difference or the maximum tank temperature is reached.

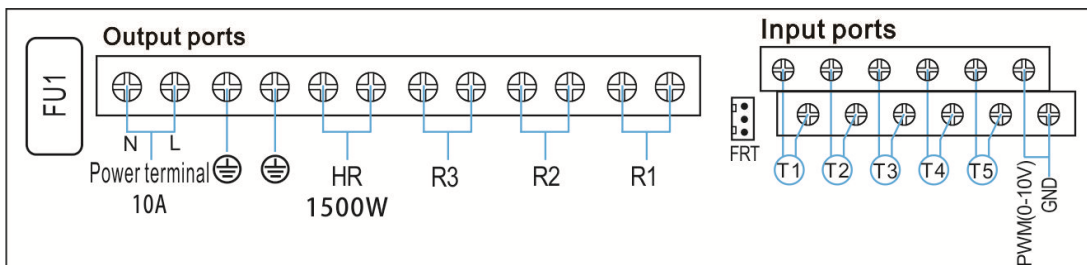
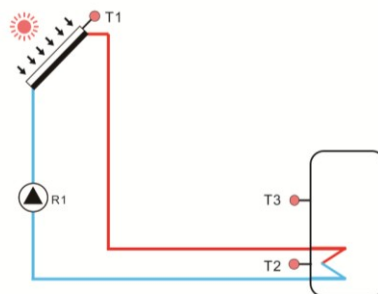

Sensor	Description	Relay	Description
T1	Temperature of collector Pt1000	R1	Solar circulation pump
T2	Temperature of tank base NTC10K	HR	Back up heating
T3	Temperature of tank upper (selectable) NTC10K		

Auxiliary function

Code	Description	Object sensor	Object relays
CIRC	DHW circulation (controlled by temperature or flow impulse)	T4/flow switcher (connected on T4 port)	R2
OHDP	Thermal transfer -by external radiator		R2/R3(selectable)
TIME	Timer function		R3
AH	Thermostat function	T2/T3/T5(selectable)	R3
QHQM	The heat measurement	T4 return temperature sensor T5 flow temperature sensor	

i Note:

Sometime, for one selected function, it needs an extra input to connect temperature sensor or an extra output to control pump or electromagnetic valve, in the case all inputs and

outputs are in using, and then this selected function will not be triggered even when you have activated it. Controller can distinguish it automatically and switch-off this function.

1. When one of these functions (TIME, AH) is activated, and then the other one will be deactivated automatically.
2. After CIRC function is activated, if OHDP function is activated also and R2 output is selected for it, and then CIRC will be deactivated automatically.

5. Function's parameters and options

5.1 Overview of menu structure

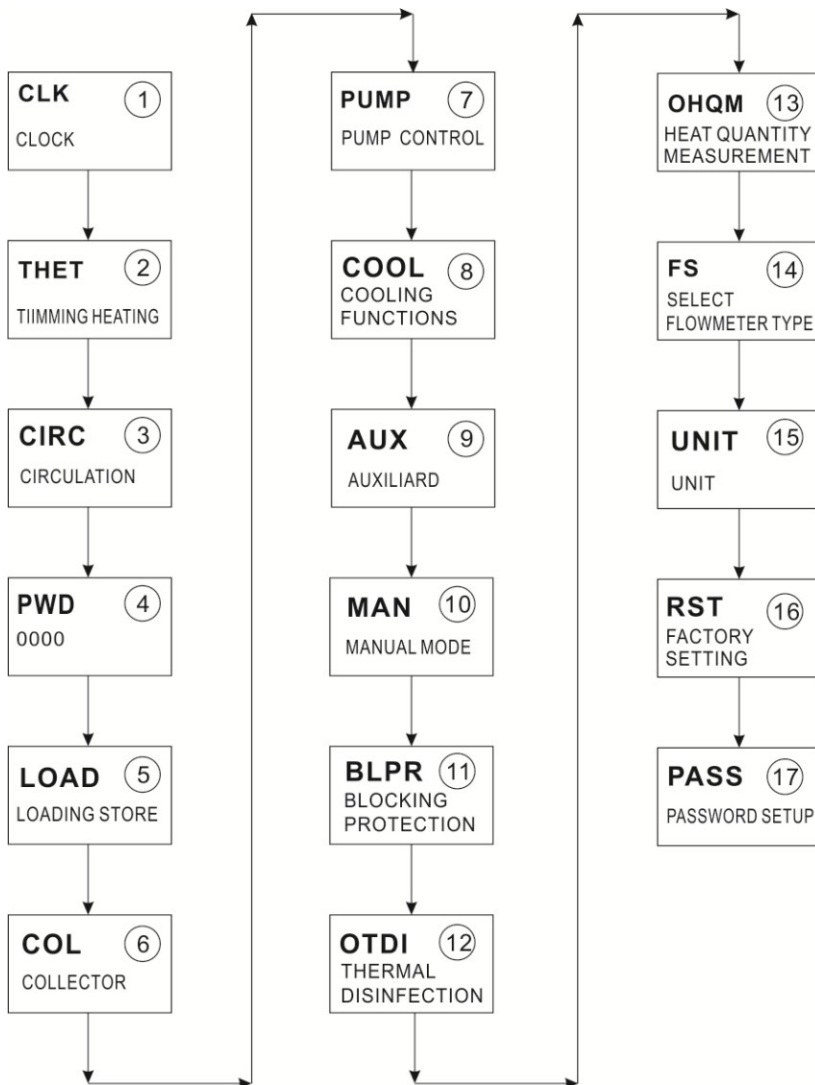

5.2 Menu operation description

- Access main menu
 - ▶ Press “SET” button to access main menu
 - ▶ Press “▲/▼” to select menu
 - ▶ Press “SET” button to enter the submenu

- Access submenu
 - ▶ After selecting main menu, then press “SET” button to access submenu
 - ▶ Press “▲/▼” button to select submenu,
 - ▶ Press “SET” button to enter the value adjust interface or selection function (select ON/OFF)
 - ▶ Press “▲/▼” to adjust value
 - ▶ Press “SET” or ”ESC” to confirm the value you set
 - ▶ Press “ESC” to exit the submenu

 **Note:** Enter the menu adjustment interface, if you don't press any button in 3 minutes, screen will exit the adjustment and return to the main interface.

5.3 Value checking

At the normal operation mode, press “▲/▼” button, you can view the temperature of collector(T1) and tank(T2,T3), pump speed(n1%), Accumulated running time of pump (hR1), flow rate(L/M), the controller operation time(DAYS),and firmware version(SW).

 **Note:**

- 1.For the countdown time of disinfection, auxiliary function, you can only check them when the function is activated in the parameter menus.
- 2.After activated the OHQM function, you can check You can query the heat of the day (DKWH), cumulative heat kilowatt hour (KWH), and megawatt hour (MWH) .
3. At the value check interface, if you don't press any button within 3 minutes, screen will exit the check interface and return to the main interface.

6. Functions operation and parameters setting (for user)

6.1 CLK Time setup

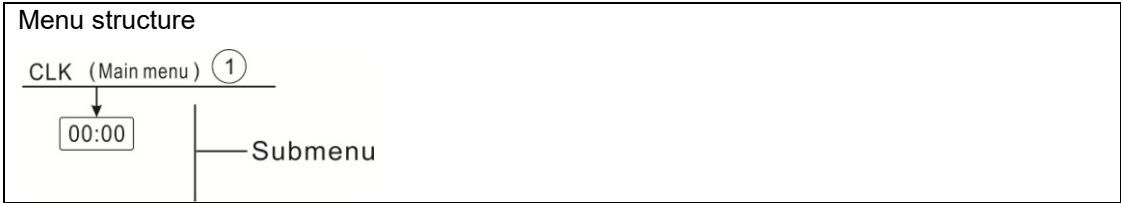

- ▶ Press “SET” button, select CLK menu
- ▶ Press “SET” button, hour “00” blinks on the display.
- ▶ Press “▲/▼” button to adjust hour
- ▶ Press “SET” button, minute time “00” blinks on the display
- ▶ Press “▲/▼” button to adjust minute
- ▶ Press “SET” or “ESC” button to save the set value



i **Note:** In the case power to controller is switched-off, date and time will be remembered in controller for 36 hours.

6.2 THET Timing heating

Electrical back-up heater, gas boiler or oil boiler can be installed in the solar system to ensure the tank’s temperature meets the required temperature, this electrical heater can be controlled automatically by this controller, when tank temperature **T3** drops below the switch-on set point of this function, electrical heater HR is triggered to heat tank up to the switch-off temperature, and then electrical heater HR stops working.

i **Note:** the reference sensor T3 or T2 of this function can be selected in parameter THTS.

It is possible to set three time sections for activating this function,

Factory default set:

- The first time section: heating starts at 4:00am, stops at 5:00am, and switch on temperature is set at 40°C, switch-off temperature is set at 50°C
- The second time section: heating starts at 10:00am, stops at 10:00am
- The third time section: heating starts at 17:00am, stops at 22:00am, and switch on temperature is set at 50°C, switch-off temperature is set at 55°C

If you want to shut off one timing heating ,then you can set the turning on time and turning off time with a same value(for example, set second start time tA2 O at 10:00 and set the stop

time tA2 F at 10:00)

Every day three timing heating can be set, and the switch-on temperature adjustable range is 0°C ~ (OFF-2°C), switch-off temperature adjustable range is (ON+2°C) ~ 95°C.

● **Intelligent heating mode**

In the case the solar irradiation isn't enough to heat the tank, in order to ensure the tank temperature meets the requirement, controller will check the temperature of tank at the specified time, if temperature doesn't rise to the required value, and controller will trigger the electrical heater to heat tank until its temperature rises up to the default switch-off temperature.

Default set (not adjustable):

The first time: starts heating at 13:00 until temperature of 30 °C.

The second time: starts heating at 14:00 until temperature of 35 °C.

The third time: starts heating at 15:00 until temperature of 40 °C.

The fourth time: starts heating at 16:00 until temperature of 45 °C.

The fifth time: starts heating at 17:00 until temperature of 50 °C.

i Note: If customer use electrical heater as back-up, please according to the power of electrical heater to equip corresponding safety devices like contactor and breaker with this controller, we strongly recommend equipping with SR802 device with this controller, (SR802 detailed technical data see item 10 Accessories)

Menu structure					
THET (Main menu) ②					
Main menu	Submenu	Factory set	Adjustable range	Step per adjust	Description
THET					Timing heating
	THS	S2	S2. S3		Select desired sensor for timing heating function (S3 for T3, S2 for T2)
	SMT	ON	ON/OFF		Intelligent timing heating
	tH10	04:00 /40°C	00:00-23:59/0°C ~(OFF-2°C)	0.5°C	Switch-on time and temperature of the first

					timing heating
	tH1F	05:00/50°C	00:00-23:59/(ON +2°C) ~95°C	0.5°C	Switch-off time and temperature of the first timing heating
	t H2O	10:00/40°C	00:00-23:59/0°C ~ (OFF-2°C)	0.5°C	Switch-on time and temperature of the second timing heating
	tH2F	10:00/50°C	00:00-23:59/(ON +2°C) ~95°C	0.5°C	Switch-off time and temperature of the second timing heating
	tH3O	17:00/50°C	00:00-23:59/0°C ~ (OFF-2°C)	0.5°C	Switch-on time and temperature of the third timing heating
	tH3F	22:00/55°C	00:00-23:59/(ON +2°C) ~95°C	0.5°C	Switch-off time and temperature of the third timing heating

Function setting:

▶ Press “SET” button to access main menu, and press “▲” to select THEH timing heating main menu.



▶ Press “SET” button to set parameter, select the reference sensor of tank, “THS S2” displays on the screen.



▶ Press “SET” button, “S2” blinks

▶ Press “▲/▼” button to select desired sensor (S3 for T3, S2 for T2)

▶ Press “SET” or “ESC” button to save the setting.

▶ Press “▲” button, to access intelligent heating mode, “SMT OFF” displays on the screen



▶ Press “SET” button, “OFF” blinks

▶ Press “▲/▼” button to activate this function.

▶ Press “▲” button to set start time of the first time section, “tH1O 04:00” displays on the screen

▶ Press “SET” button, hour time “04” blinks

▶ Press “▲/▼” button to adjust hour of the switch-on time

▶ Press “SET” button, minute time “00” blinks

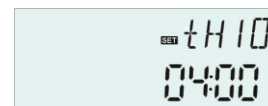

▶ Press “▲/▼” button to adjust minute of the switch-on time

▶ Press “SET” button, to set the switch on temperature, “40°C” blinks

▶ Press “▲/▼” button to adjust the switch-on temperature.

▶ Press “SET” or “ESC” button to save the setting.

▶ Press “▲” button to set stop time of the first time section, “tH1F 05:00” displays on the



screen

- ▶ Press “SET” button, hour time “05” blinks
- ▶ Press “▲/▼” button to adjust hour of the switch-off time
- ▶ Press “SET” button, minute time “00” blinks
- ▶ Press “▲/▼” button to adjust minute of the switch-off time
- ▶ Press “SET” button, to set the switch off temperature, “45°C” blinks
- ▶ Press “▲/▼” button to adjust the switch-off temperature.
- ▶ Press “SET” or “ESC” button to save the setting.
- ▶ Press “▲” button to access the window of the switch-on time of the second time section, repeat above steps to set time and temperature for the second and third time section.



When heating sign  blinks on the screen, it indicates that timing-heating function is activated.

i **Note:** The Sign  represents whether timing heating function is on or off.

1. Within the preset time section, heating sign  is lighted on the screen
2. Out of the preset time section, heating sign  doesn't display on the screen.

6.3 CIRC DHW circuit pump controlled by temperature in three time - sections / flow switcher

i **Note:** Since the input port T4 and T5 temperature sensors need to be occupied after the heat measurement function (OHQM) is activated, the water circulation function (CIRC) and heat measurement can not available at the same time.

Function description:

This function is designed to get warm water quickly when customer open the stopcock. In the case stopcock is closed, hot water pipe is also used as the circuit pipe. Two hot water circuit supply modes are available, temperature controlled mode and flow switcher controlled mode. For using this function, an extra circuit pump R2 and a flow switcher or a temperature sensor (mounted on the hot water return pipe (T4) should be installed in the system.

2 control mode of DHW circuit pump are designed in this controller: temperature control in three time sections and flow switch control in three time sections.

● **Three time - sections/ temperature control mode (tEP)**

Within the time - section (default: DHW temperature is less than 40oC, DHW circuit pump is trigger, when temperature rises to 45oC, DHW circuit pump is stopped).

Trigger on conditions of temperature controlled DHW circuit pump (STAT): when tank temperature (T2 or T3, T3 is prior control) is 2oC higher than the preset switch-off temperature (CYCF) of this function, DHW pump just can be triggered.

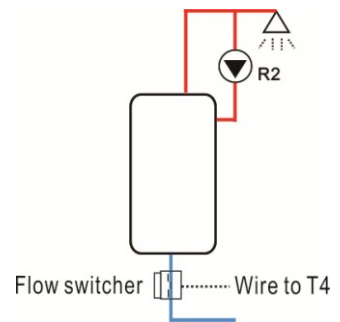

Default time - section set:

The first time - section: start at 05:00 and stops at 07:00a.m

The second time - section: starts at 11:00 and stops at 13:00

The third time - section: starts at 17:00 and stops at 22:00 p.m.



Note:

1. for 2 DHW circuit pump control modes, only one mode can be selected.
2. If this sensor(T4) is necessary to be installed in the system, in order to avoid the measure error, please ensure its position is 1.5m far to the tank.
3. for 2 DHW control modes, three time - sections/temperature control mode and three time - sections /flow switcher control mode, their parameter adjust steps of two control mode are same.

Three time - sections/ flow switcher control mode FS

Function description:

Open the stopcock, water flows through pipe, a flow signal is felt by a flow switcher which is mounted on the cold-water pipe and sent to the controller, and then controller will trigger the DHW circuit pump (R2) and it pumps hot water from tank to the circuit pipe. The running time of circuit pump is adjustable, when the preset time runs out, pump stops.

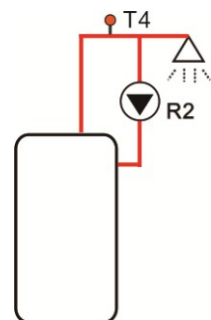

This stopcock seems like a remote controller to control the running of circuit pump. This operation mode is an environment-friendly, energy-saving control solution.

Open the stopcock for a shortly time, the flow switcher which is mounted on the cold flow pipe of tank will feel the flow signal, and then controller will trigger the circuit pump R2, and pump will feed hot water from tank to the pipe. Then when you re-open the stopcock, hot water flows out immediately. Once the pump's running time finishes, then pump is stopped. When hot water is not used, to avoid the heat releasing through pipe due to the running of circuit pump, controller will stop the pump after the pre-set running time. To avoid the pump being re-triggered just after it stopped, parameter "rest time" is used for this control.

Open the stopcock within a pre-set time - section, pump running as the default design: pump

running for every three minutes and then rest for 15minutes (the adjustable range of the running time is 1-30 MIN and the rest time is 0-60MIN

 Note:

- 1.Installed a checkvalve on the inlet pipe of circuit pump to avoid the water which is from tank mixing with water from circuit pipe.
- 2.If the stop time is set with value 0 minute, then when flow switcher feels the flow and thus to trigger the pump, pump will run for the whole time - section. And when the stopcock is closed, pump is stopped automatically.

Default time - section set:

The first time - section: start at 05:00 and stops at 07:00a.m

The second time - section: starts at 11:00 and stops at 13:00

The third time - section: starts at 17:00 and stops at 22:00 p.m.

Flow switch fitting:

Material of fitting: brass

House: plastic

Connection: G3/4

Reed of flow switch: Max 300V DC/1A



 Note:

1. Note the flow direction indicated on the flow switch!
2. Lead the wires from flow switcher to input ports of controller, no polarity required.
3. Flow switch is not included in the delivery list of this controller, please buy it separately.

Menu structure:

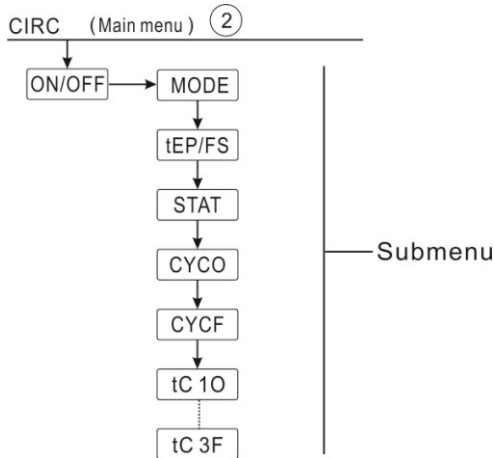

Main menu	Submenu 1	Submenu 2	Factory set	Adjustable range	Step per adjust	Description
CIRC			OFF	ON/OFF		DHW circuit function
	MODE	FS	tEP/FS			Control mode by temperature or by flow switcher.
		STAT	ON	ON/OFF		Trigger condition of DHW circuit pump Tank temperature (T3 or T2, T3 was priority) is 2°C higher than the switch-off temperature
		CYCO	40C/3min	5-53C/1-30 min	0.5C/1 min	Switch-on temperature or running time
		CYCF	45C/15min	7-55C/0-60 min	0.5C/1 min	Switch-off temperature or the rest time
		t C1O	05:00	00:00-23:59		Switch-on time and temperature for the first time section
		t C1F	07:00	00:00-23:59		Switch-off time and temperature for the first time section
		t C2O	11:00	00:00-23:59		Switch-on time and temperature for the second time section
		t C2F	13:00	00:00-23:59		Switch-off time and temperature for the second time section
		t C3O	17:00	00:00-23:59		Switch-on time and temperature for the third time section

		t C3F	22:00	00:00-23:59		Switch-off time and temperature for the third time section
--	--	-------	-------	-------------	--	--

Function setup: (take temperature controlled DHW as example)

▶ Select main menu CIRC DHW circuit function



▶ Press "SET" button, "CIRC OFF" displays on the screen.

▶ Press "SET" button, "OFF" displays on the screen.

▶ Press "▲/▼" button to activate this function "CIRC ON" displays on the screen



▶ Press "SET" or "ESC" button to save the setting

▶ Press "▲" button, "MODE FS" displays on the screen (select time control mode)

▶ Press "SET", "FS" blinks

▶ Press "▲/▼" button to select time control mode.

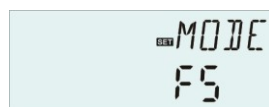

▶ Press "SET" or "ESC" button to save the setting.

▶ Press "▲" button, "STAT ON" displays on the screen (condition of pump trigger -on, only available at three time - sections temperature control mode)

▶ Press "SET" button, "ON" blinks (default set is ON, activate this function)



▶ Press "▲/▼" button to deactivate the function.

▶ Press "SET" or "ESC" button, to confirm the setting

▶ Press "▲", "CYCO 40oC" displays on the screen (if flow control mode CYFS ON, then here displays "CYCO 03Min", here take temperature as example)

▶ Press "SET" button, "40oC" blinks

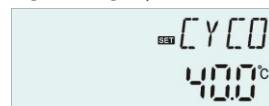

▶ Press "▲/▼" button to adjust the switch-on temperature of DHW circuit pump, adjustable range 0oC ~ (OFF-2oC).

▶ Press "SET" or "ESC" button, to confirm the setting

▶ Press "▲", "CYCF 45oC" displays on the screen

▶ Press "SET" button, "45oC" blinks



▶ Press "▲/▼" button to adjust the switch-off temperature of DHW circuit pump, adjustable range (ON+2oC) ~55C

▶ Press "SET" or "ESC" button, to confirm the setting

▶ Press “▲”, “tC1O 05:00” displays on the screen, to set the start time of the first time-section.

▶ Press “SET” button, hour time “05” blinks

▶ Press “▲/▼” button to adjust time hour of the start time of the first time-section

▶ Press “SET” button, minute time “00” blinks

▶ Press “▲/▼” button to adjust time minute of the start time of the first time-section

▶ Press “SET” or “ESC” button, to confirm the setting



▶ Press “▲”, “tC1F 07:00” displays on the screen, to set the close time of the first time-section.

▶ Press “SET” button, hour time “07” blinks

▶ Press “▲/▼” button to adjust time hour of the close time of the first time-section

▶ Press “SET” button, minute time “00” blinks

▶ Press “▲/▼” button to adjust time minute of the close time of the first time-section

▶ Press “SET” or “ESC” button, to confirm the setting



▶ Press “▲”, to access the setting of the start time of the second time-section, doing like above described steps to set the start and close time of second and third time-section.

If it is needed to close one time-section, then just set the start time and close time with a same time. (example: at 10:00 start circuit, and at 10:00 close the circuit)

7. Function operation and parameter setup (engineer)

7.1 PWD Password



Access main menu, select “PWD 0000” to enter password

- ▶ Press “SET” button, the left digital blinks, enter password, factory set is “0000”
- ▶ Press “▲/▼”, to enter the first digital
- ▶ Press “SET”, the second digital blinks
- ▶ Press “▲/▼” to enter the second digital
- ▶ Press “SET”, the third digital blinks
- ▶ Press “▲/▼” to enter the third digital
- ▶ Press “SET”, the fourth digital blinks
- ▶ Press “▲/▼” to enter the fourth digital
- ▶ Press “SET”, to access main menu



Through password set to limit the user to change some parameters, 4 digitals needed.
Default is 0000

If no password is set, then just press “SET” five times to access main menu directly

7.2 LOAD tank heating

Function description:

- **ΔT control logic**

The controller works as a standard temperature differential controller. If the temperature reaches or exceeds the switch-on temperature difference (DTO), the pump R1 switches on. When the temperature difference reaches or falls below the adjusted switch-off temperature difference (DTF), the respective relay of R1 switches off.

i Note: The switch-on temperature difference must be 0.5 K higher than the switch-off temperature difference. The set temperature difference must be at least 0.5 K higher than the switch-on temperature difference.

- **Speed control**

If the temperature reaches or exceeds the switch-on temperature difference, the pump switches on at 100% speed for 10s. Then, the speed is reduced to the minimum pump speed value. If the temperature difference reaches the preset temperature difference, the pump speed increases by one step (10%). The response of the controller can be adapted via the parameter RIS. If the difference increases by the adjustable rise value RIS, the pump speed increases by 10% until the maximum pump speed of 100% is reached. If the temperature difference decreases by the adjustable rise value (RIS), pump speed will be decreased by one step 10% accordingly.

i Note: To enable speed control function, the corresponding pump type has to be set to

(MIN, MAX) and relay control has to be set to (PULS, PSOL, PHEA or 0-10 V) (under adjustment menu PUMP).

● **SMX Maximum tank temperature protection set**

If the tank temperature reaches its adjusted maximum temperature, the tank will no longer be loaded in order to avoid damage caused by overheating. If the maximum tank temperature is exceeded, sign  is displayed on the screen.

The sensor for tank maximum limitation (SMAX) can be selected. The maximum limitation always refers to the sensor selected (T2 or T3). The switch-on hysteresis (HYST) is selectable(Default is 2°C), for example, when tank maximum temperature is set to 70°C, then at 68°C, tank Maximum temperature protection function is deactivated automatically.

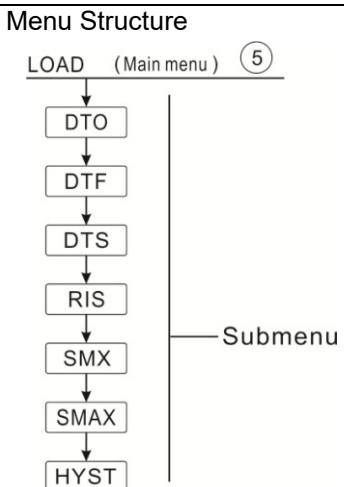
Menu Structure					
					
Main menu	Submenu	Factory set	Adjustable range	Step per adjust	Description
LOAD					Tank heating
	DTO	6K	1-50K	0.5K	Switch-on temperature difference of tank heating
	DTF	4K	0.5-49.5K	0.5K	Switch-off temperature difference of tank heating
	DTS	10K	1.5-50K	0.5K	Temperature difference of pump speed control
	RIS	2K	1-20K	1K	Rise range of pump speed control
	SMX	70°C	4-95°C	1°C	Maximum temperature of tank
	SMAX	S2	S2. S3		Sensor for Maximum temperature of tank (S3 for T3, S2 for T2)

	HYST	2K	0.1-10K	0.1K	Hysteresis of maximum temperature of tank
--	------	----	---------	------	---

Setup the functions

▶ Select "LOAD" main menu



▶ Press "SET", "DTO 6K" displays on the screen



▶ Press "SET", "6K" blinks

▶ Press "▲/▼", to adjust the switch-on temperature of the solar circuit pump.

▶ Press "SET" or "ESC" to save the setting



▶ Press "▲", "DTF 4K" displays on the screen

▶ Press "SET", "4K" blinks

▶ Press "▲/▼", to adjust the switch-off temperature of solar circuit pump

▶ Press "SET" or "ESC" to save the setting



▶ Press "▲", "DTS 10K" displays on the screen

▶ Press "SET", "10K" blinks

▶ Press "▲/▼", to adjust the standard temperature difference of solar circuit pump

▶ Press "SET" or "ESC" to save the setting

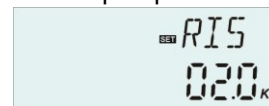

▶ Press "▲", "RIS 2K" displays on the screen

▶ Press "SET", "2K" blinks

▶ Press "▲/▼", to adjust the rise range of pump speed control

▶ Press "SET" or "ESC" to save the setting



▶ Press "▲", "SMX 70°C" displays on the screen

▶ Press "SET", "70°C" blinks

▶ Press "▲/▼", to adjust the maximum temperature of tank

▶ Press "SET" or "ESC" to save the setting



▶ Press "▲", "SMAX S2" displays on the screen

▶ Press "SET", "S2" blinks

▶ Press "▲/▼", select the sensor for maximum temperature of tank (S3 for T3, S2 for T2)

▶ Press "SET" or "ESC" to save the setting



▶ Press "▲", "HYST 2K" displays on the screen

▶ Press "SET", "2K" blinks



▶ Press "▲/▼", to adjust the hysteresis of tank maximum temperature

▶ Press "SET" or "ESC" to save the setting

7.3 COL Collector function

Function description

- **OCEM Collector emergency shutdown**

When the collector temperature exceeds the adjusted collector emergency temperature, Then solar pump (R1) switches off in order to protect the system components against overheating (collector emergency shutdown). If the maximum collector temperature (OCEM) is exceeded, sign   is displayed.

 **Warning!** Risk of injury! Risk of system damage by pressure surge! If water is used as the heat transfer fluid in pressurized systems, water will boil at 100 °C. Then do not set the collector limit temperature higher than 95 °C.

- **OCCO Collector cooling**

The collector cooling function keeps the collector temperature rising within the operating range by heating the tank. If the tank temperature reaches 95°C the function will be switched off for safety reasons.

When the tank temperature exceeds the adjusted maximum temperature of tank, then solar system is switched off. If the collector temperature rises up to its adjusted maximum collector temperature, the solar pump is switched on again until the collector temperature falls below the maximum collector temperature. The tank temperature may then exceed its maximum temperature, but only up to 95°C (emergency shutdown of the tank), and sign  blinks on the screen, system stops.

If the collector cooling is active,  blinks on the screen.

This function is only available when the system cooling function (OSYC) and the heat transfer function (OHDP) are not activated.

- **OCMI Collector minimum temperature**

The minimum collector temperature is the lowest temperature for running the solar system, only when collector temperature is higher than this temperature, solar pump (R1) just can be switched-on, if the collector temperature falls below the adjusted minimum temperature, and the function will be activated, sign  blinks on the screenslowly.

- **OCFR Collector antifreeze function**

Collector antifreeze function activates the loading circuit between the collector and the tank when the collector temperature falls below the adjusted temperature **CFRO**. This will protect the fluid against freezing or coagulating. If collector temperature exceeds the switch-off temperature of collector antifreeze function **CFRF**, the solar pump will be switched off again.

If collector antifreeze function is activated, sign ❄️ blinks on the screen slowly.

i Note: Since this function uses the limited heat which is saved in the tank, so the antifreeze function should be used in regions where ambient temperatures is around the freezing point only for a few days.

● **OTCO Tube collector function**

This function is used for improving the switch-on behavior in systems with non-ideal sensor positions (e. g. with some tube collectors).

This function operates within an adjusted time section. It activates the collector circuit pump R1 for an adjustable runtime between adjustable pauses in order to compensate for the delayed temperature measurement.

If the runtime is set to more than 10s, the pump will run at 100% for the first 10s of the runtime. For the remaining runtime, the pump will run at the adjusted minimum speed.

If the collector sensor is defective or the collector is blocked, this function will be switched off.

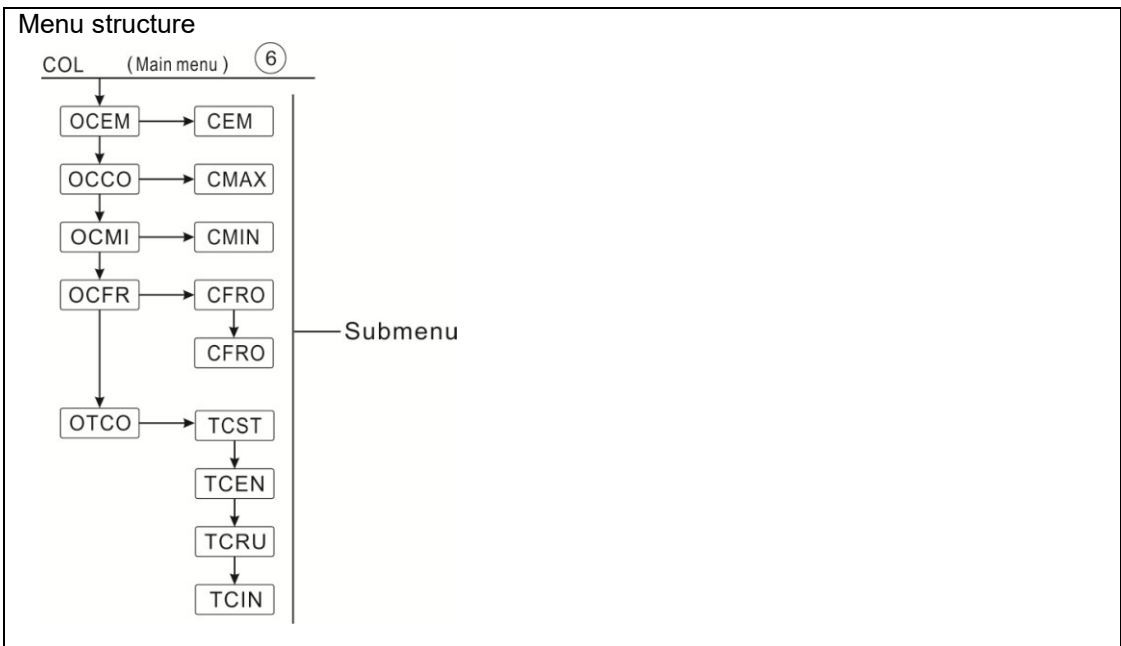

Main menu	Submenu 1	Submenu 2	Factory set	Adjustable range	Step per adjust	Description
COL						Collector function
	OCEM		ON			Collector emergency shutdown function on/ff
		CEM	130°C	80-200°C	1°C	Temperature of collector emergency shutdown(hysteresis 10K)
	OCCO		OFF			Collector cooling function on/off
		CMAX	110°C	70-160°C	1°C	Temperature of collector cooling (hysteresis 5K)
	OCMI		OFF			Collector minimum temperature function on/off
		CMIN	10°C	10-90°C	1°C	Temperature of collector minimum function(hysteresis5°C)
	OCFR		OFF			Anti-freeze function on/off
		CFRO	4°C	-40-8°C	0.5°C	Switch-on temperature of anti-freeze function
		CFRF	5°C	-39-9°C	0.5°C	Switch-off temperature of anti-freeze function
	OTCO					Tube collector function
		TCST	07:00	00:00-23:00	1min	Start time of tube collector function
		TCEN	19:00	00:00-23:00	1min	Stop time of tube collector function
		TCRU	30s	30-300s	1s	Pump runtime during tube collector function
		TCIN	30min	5-60min	1min	Pump stop time during tube collector function

Function setting:

OCEM (Collector emergency shutdown function) setup

- ▶ Select "COL" function menu
- ▶ Press "SET", "OCEM" displays on the screen
- ▶ Press "SET" again, "OCEM ON" displays on the screen
- ▶ Press "SET", "ON" blinks on the screen



(If it is necessary to shut down this function, press “▲/▼” to deactivate it)

- ▶ Press “SET” or “ESC” to save the setting
- ▶ Press “▲”, “OCEM 130°C” displays on the screen
- ▶ Press “SET”, “130°C” blinks on the screen
- ▶ Press “▲/▼”, to activate or deactivate the collector emergency function
- ▶ Press “SET” or “ESC” to save the setting
- ▶ Press “ESC” to return to the previous menu



☰ OCEM
1300°C

OCCO (Collector cooling function) setup

- ▶ Press “▲”, “OCCO” displays on the screen
- ▶ Press “SET”, “OCEM OFF” displays on the screen
- ▶ Press “SET”, “OFF” blinks on the screen
- ▶ Press “▲/▼”, to activated this function, “OCEM ON” displays on the screen
- ▶ Press “▲”, “CMAX 110°C” displays on the screen
- ▶ Press “▲/▼”, to adjust the switch-on temperature of collector cooling function
- ▶ Press “SET” or “ESC” to save the setting
- ▶ Press “ESC” to return to previous menu



☰ OCCO



☰ OCEM
OFF



☰ CMAX
1100°C

OCMI (Collector minimum temperature) setup

- ▶ Press “▲”, “OCMI” displays on the screen
- ▶ Press “SET”, “OCMI OFF” displays on the screen
- ▶ Press “SET”, “OFF” blinks on the screen
- ▶ Press “▲/▼”, to activate this function, “OCMI ON” displays on the screen
- ▶ Press “▲”, “OCMI 10°C” displays on the screen
- ▶ Press “▲/▼”, to adjust the minimum temperature of collector
- ▶ Press “SET” or “ESC” to save the setting
- ▶ Press “ESC” to return to previous menu



☰ OCMI



☰ OCMI
OFF



☰ CMIN
100°C

OCFR (Antifreeze function) setup

- ▶ Press “▲”, “OCFR” displays on the screen
- ▶ Press “SET”, “OCFR OFF” displays on the screen



☰ OCFR

- ▶ Press “SET”, “OFF” blinks on the screen
- ▶ Press “▲/▼”, to activate this function, “OCFR ON” displays on the screen
- ▶ Press “▲”, “CFRO 4°C” displays on the screen
- ▶ Press “SET”, “4°C” blinks on the screen
- ▶ Press “▲/▼”, to adjust the switch-on temperature of antifreeze function
- ▶ Press “SET” or “ESC” to save the setting
- ▶ Press “▲”, “CFRF 5°C” displays on the screen
- ▶ Press “SET”, “5°C” blinks on the screen
- ▶ Press “▲/▼”, to adjust the switch-off temperature of antifreeze function
- ▶ Press “SET” or “ESC” to save the setting
- ▶ Press “ESC” to return to the previous menu



OCFR
OFF



CFRO
040°C



CFRF
050°C

OTCO (Tube collector function) setup

- ▶ Press “▲”, “OTCO” displays on the screen
- ▶ Press “SET”, “OTCO OFF” displays on the screen
- ▶ Press “SET”, “OFF” blinks on the screen
- ▶ Press “▲/▼”, to activated this function, “OTCO ON” displays on the screen
- ▶ Press “▲”, “TCST 07:00” displays on the screen
- ▶ Press “SET”, “07” blinks
- ▶ Press “▲/▼”, to adjust hour
- ▶ Press “SET”, “00” blinks on the screen
- ▶ Press “▲/▼”, to adjust minute
- ▶ Press “SET” or “ESC” to save the setting
- ▶ Press “▲”, “TCEN 19:00” displays on the screen
- ▶ Press “SET”, “19” blinks
- ▶ Press “▲/▼” to adjust hour
- ▶ Press “SET”, “00” blinks
- ▶ Press “▲/▼”, to adjust minute
- ▶ Press “SET” or “ESC” to save the setting
- ▶ Press “▲”, “TCRU 30” displays on the screen
- ▶ Press “SET”, “30” blinks
- ▶ Press “▲/▼”, to adjust runtime



OTCO



OTCO
OFF



TCST
07:00



TCEN
19:00



TCRU
30

- ▶ Press “SET” or “ESC” to save the setting
- ▶ Press “▲”, “TCIN 30Min” displays on the screen
- ▶ Press “SET”, “30” blinks
- ▶ Press “▲/▼”, to adjust stop time
- ▶ Press “SET” or “ESC” to save the setting
- ▶ Press “ESC” to return to the previous menu



7.4 PUMP Pump R1 control mode

Function description:

With this parameter, the relay control mode can be adjusted. The following modes can be selected:

- Adjustment for standard pump without speed control:
ONOF: Pump on / pump off
 - Adjustment for standard pump with speed control:
PULS: Burst control via semiconductor relay
 - Adjustment for high-efficiency pump (HE pump)
- PSOL: PWM profile solar pump

PWM signal logic (solar):

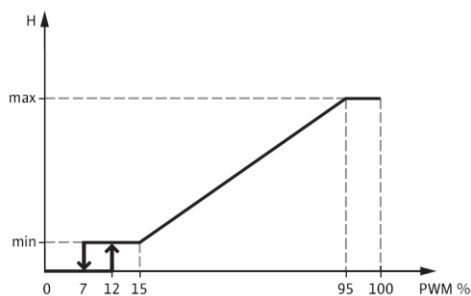

- PHEA: PWM profile heating pump

PWM signal logic (heating):

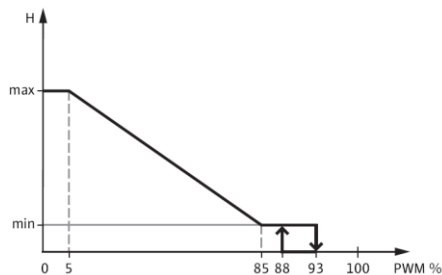

- 0-10: Speed control via 0 - 10 V signal

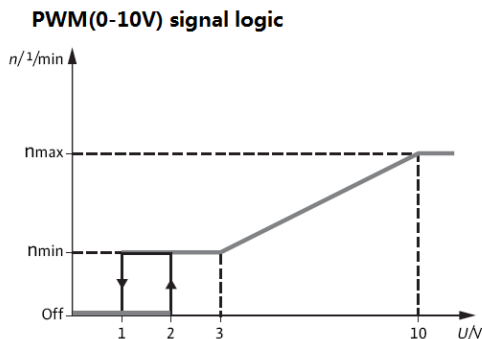

Note:

1. More information about connection of high efficiency pump see the paragraph (3.5 Connection with high efficiency pump)
2. Minimum pump speed: Under the adjustment menu MIN1, a relative minimum speed for connected pumps can be allocated to the outputs R1.
3. Maximum pump speed: Under the adjustment menu MAX1, a relative maximum speed for connected pumps can be allocated to the outputs R1.
4. When the devices which are not speed-controlled are used (e. g. motored valves), the pump speed value of the corresponding relay must be set to 100 % or the control Mode must be set to ONOF in order to deactivate pump speed control.

Menu structure						
Main menu	Submenu 1	Submenu 2	Factory set	Adjustable range	Step per adjust	Description
PUMP						Pump control mode
	ONOF		ON	ON/OFF		Pump on/off (for pump without speed control)
	PULS		OFF	ON/OFF		Pulse control (Burst

		MIN1	50%	20-95%	5%	control via semiconductor relay for Pump with speed control
		MAX1	100%	25-100%	5%	
	PSOL		OFF	ON/OFF		PWM Solar pump
		MIN1	50%	20-95%	5%	
		MAX1	100%	25-100%	5%	
	PHEA		OFF	ON/OFF		PWM DHW pump
		MIN1	50%	20-95%	5%	
		MAX1	100%	25-100%	5%	
	0-10		OFF	ON/OFF		0-10V signal control pump speed
		MIN1	50%	20-95%	5%	
		MAX1	100%	25-100%	5%	

Function setup

- ▶ Select “PUMP” menu
- ▶ Press “SET”, “ONOF ON” displays on the screen
- ▶ Press “▲/▼”, to select pump type “PLUS、PSOL、PHEA、0-10V”
- ▶ After select pump type, press “SET” to access the pump type.
- ▶ Press “SET”, “OFF” blinks on the screen
- ▶ Press “▲/▼” to open
- ▶ Press “SET” or “ESC” to save the setting
- ▶ Press “ESC” to return to previous menu



i Note:

Only 1 type can be selected from 5 types ONOF、PULS、PSOL、PHEA、0-10V

Example: when “PULS ON” open option is selected, then other four types are closed automatically.

7.5 COOL Cooling function

Function description:

There are 3 cooling functions can be activated for 3 different devices: system cooling, tank cooling, heat transferring by external radiator.

● OSYC System cooling

The system cooling function aims to keep the lifetime of a solar system for a longer time. The function overrides the maximum tank temperature limitation to provide thermal relief of the

collector field and the heat transfer fluid on hot days. If the tank temperature is higher than the adjusted maximum tank temperature and the switch-on temperature difference **DTCO** is reached, the solar pump remains running or will be switched on. Solar loading is continued until either the temperature difference falls below the adjusted switch-off value **DTCF** or the collector emergency shutdown temperature **OCEM** is reached.

i **Note:** This function will only be available when the collector cooling function, external radiator heat transfer functions are not activated.

- **OSTC Tank cooling**

When the tank cooling function is activated, the controller aims to cool down the tank during the night in order to prepare it for solar loading on the following day. If the tank temperature exceeds the adjusted maximum tank temperature **SMAX**, the collector temperature falls below the tank temperature and down to the switch-on temperature difference **DTCO** of this cooling function, then system will be activated in order to cool down the tank by releasing the energy through the collector.

If tank cooling function is activated, sign  blinks on the screen

i **Note:** if tank temperature reaches to 95 °C, all cooling functions will be locked. Hysteresis switch on temperature difference is 5K.

- **OHDP Heat transferring by external radiator**

Heat transferring by external radiator function is designed to transfer the excess heat which is generated under the strong solar irradiation through an external heat exchanger (e. g. fan coil); the purpose is to keep the collector's or tank's temperature within the operating range.

For this function, an extra output should be added (R2 or R3 as option)

Heat transferring by external radiator function can control either an additional pump or a valve (**OTPM ON** = pump logic, **OTPM OFF** = valve logic)

Heat transferring by pump logic:

If the collector temperature reaches the switch on temperature (**OTST**), the heat transfer pump(R2/R3) on. If the collector temperature fall 5K below heat transfer temperature (**OTST**), the heat transfer pump (R2/R3) off.

Heat transferring by valve logic:

If the collector temperature reaches the switch on temperature (**OTST**), the heat transfer valve(R2/R3) and circuit pump(R1) on. If the collector temperature fall 5K below heat transfer

temperature (OTST),the heat transfer valve(R2/R3)and circuit pump(R1) off.

Below is the example of this application for reference.

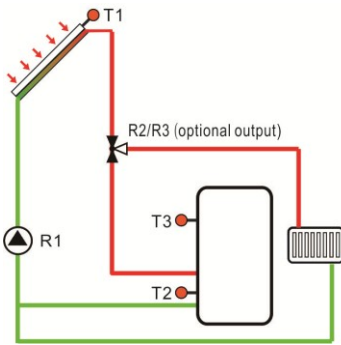

Collector heat transferring valve logic

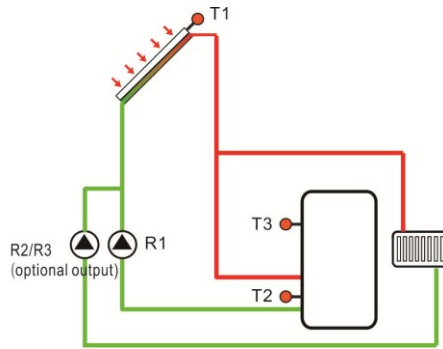

Collector heat transferring pump logic

Sign  displays on the screen, it indicates that valve logic heat transferring is running.

Sign  displays on the screen, it indicates that pump logic heat transferring is running.

i Note:

1. When collector overheat temperature OTST is 10K below the CEM temperature of collector emergency shutdown, then collector overheat temperature OTST is locked
2. Heat transferring function is only available when collector cooling function (OCCO) and system cooling function (OSYC) are deactivated.

Menu structure

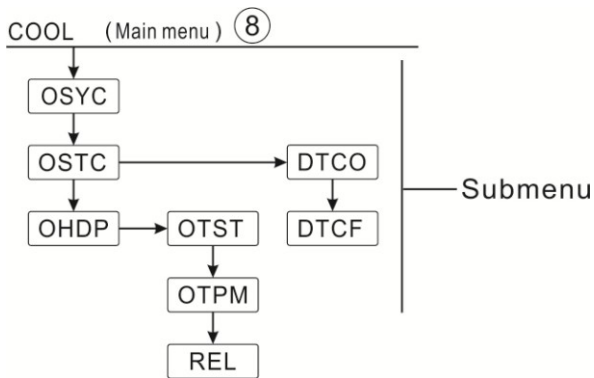

Main menu	Submenu 1	Submenu 2	Factory set	Adjustable range	Step per adjust	Description
COOL						Cooling function
	OSYC		OFF	ON/OFF		System cooling function

	OSTC		OFF	ON/OFF		Tank cooling function
		DTCO	20K	1-30K	0.5K	Switch-on temperature difference of cooling function
		DTCF	15K	0.5-29.5K	0.5K	Switch-off temperature difference of cooling function
	OHDP		OFF	ON/OFF		Heat transferring by external radiator (only in case there is available output)
		OTST	80°C	20-160°C	1°C	Temperature set point for heat transferring (hysteresis 5°C)
		OTPM	ON	OTPM ON=pump logic OTPM OFF=valve logic		Pump control logic and valve control logic
		REL	R3	R3,R2		Output ports

Function setting:

OSYC (system cooling function) setting

- ▶ Select “COOL” main menu
- ▶ Press “SET” select submenu “OSYC” .
- ▶ Press “SET”, “OSYC OFF” displays on the screen
- ▶ Press “SET”, “OFF” blinks on the screen
- ▶ Press “▲/▼”, to activate this function
- ▶ Press “SET” or “ESC” to save the setting



OSTC (Tank cooling function) setting

- ▶ Press “▲” button, “OSTC” displays on the screen
- ▶ Press “SET”, “OSTC OFF” displays on the screen
- ▶ Press “SET” button, “OFF” blinks
- ▶ Press “▲/▼” to activate this function
- ▶ Press “▲”, “DTCO 20K” displays on the screen



- ▶ Press “SET”, “20K” blinks
- ▶ Press “▲/▼”, to adjust the switch on temperature difference
- ▶ Press “SET” or “ESC” to save the setting
- ▶ Press “▲”, “DTCF 15K” displays on the screen
- ▶ Press “▲/▼”, to adjust the switch-off temperature difference
- ▶ Press “SET” or “ESC” to save the setting
- ▶ Press “ESC” to return to previous menu



OHDP (Heat transferring) setting

- ▶ Press “▲”, “OHDP” displays on the screen
- ▶ Press “SET”, “OHDP OFF” displays
- ▶ Press “SET”, “OFF” blinks
- ▶ Press “▲/▼”, to activate this function, “OHDP ON” displays
- ▶ Press “▲”, “OTST 80°C” displays
- ▶ Press “SET”, “80°C” blinks
- ▶ Press “▲/▼”, to adjust the temperature of heat transferring
- ▶ Press “SET” or “ESC” to save the setting
- ▶ Press “▲” button, “OTPM ON” displays
- ▶ Press “SET”, “ON” blinks
- ▶ Press “▲/▼”, to select the control logic pump or valve
- ▶ Press “SET” or “ESC” to save the setting
- ▶ Press “▲”, “REL 2” displays
- ▶ Press “SET”, “2” blinks
- ▶ Press “▲/▼”, to select the output port for heat transferring
- ▶ Press “SET” or “ESC” to save the setting
- ▶ Press “ESC” to return to previous menu



7.6 AUX Auxiliary function

Function description:

Auxiliary functions can be set under “AUX” menu; controller can activate several auxiliary functions simultaneously.

- **TIME Timer function**

Through function, the output relays can be triggered at a specified time, for this purpose, an output R3 should be added.

- **AH Thermostat function**



Note: When the heat measurement function (OHQM) is activated, If flow temperature

sensor(SUPS) select S5,the AH function only set object sensor T2 or T3.If AH function need select object sensor T5 ,you need to access OHQM menu and set flow temperature sensor(SUPS)at S1.

Thermostat function is independent from solar system, through output R3, it is possible to transfer the thermal energy from tank to radiator to reduce the tank temperature, or increase the tank temperature by other heat source, every day three time section can be set.

i **Note:** AHO< AHF: thermostat function is used to control the back-up heater.

AHO> AHF: thermostat function is used to transfer heat from tank to reduce tank temperature.

Sign AH displays on the screen, it indicates thermostat function is activated.

Sign AH displays on the screen, it indicates thermostat function is running.

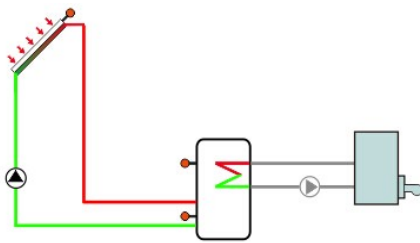

Back up heating

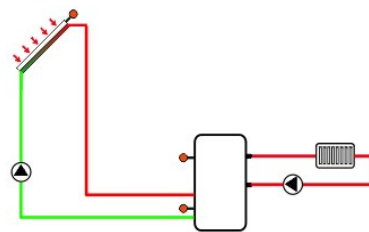

thermal energy releasing

● **BEEP Beeper fault warning**

When system has fault (temperature sensor fault, no flow), beeper sends out warning.

Main menu	Submenu 1	Submenu 2	Factory set	Adjustable range	Step per adjust	Description
AUX						Auxiliary functions

AUX (Main menu) ⑨	
TIME	ON/OFF
AH	ON/OFF
BEEP	t 10
	t 3F
AHS	
AHO	
AHF	
tA10	
tA3F	

Submenu

Operation manual of solar controller SolCon-002

	TIME		OFF	ON/OFF		Timer function
		t 1O	00:00	00:00-23:59		Start time of the first time section
		t 1F	00:00	00:00-23:59		Close time of the first time section
		t 2O	00:00	00:00-23:59		Start time of the second time section
		t 2F	00:00	00:00-23:59		Close time of the second time section
		t 3O	00:00	00:00-23:59		Start time of the third time section
		t 3F	00:00	00:00-23:59		Close time of the third time section
	AH		OFF	ON/OFF		Thermostat function
		AHS	S3	S2/S3/S5		Reference sensor selection (S3 for T3, S2 for T2, S5 for T5)
		AHO	40°C	0.0-95°C	0.5°C	Switch-on temperature of thermostat function
		AHF	45°C	0.0-94.5°C	0.5°C	Switch-off temperature of thermostat function
		t A1O	00:00	00:00-23:59		Start time of the first time section
		t A1F	23:59	00:00-23:59		Close time of the first time section
		t A2O	00:00	00:00-23:59		Start time of the second time section
		t A2F	00:00	00:00-23:59		Close time of the second time section
		t A3O	00:00	00:00-23:59		Start time of the third time section
		t A3F	00:00	00:00-23:59		Close time of the third time section
	BEEP		OFF	ON/OFF		Beeper warning function (sensor fault, no flow)

Function setup

● TIME Timer function

▶ Select AUX main menu, press “SET” to access “TIME” submenu



▶ Press “SET”, “TIME OFF” displays



▶ Press “SET”, “OFF” blinks

▶ Press “▲/▼”, to activate this function, “TIME ON” displays

▶ Press “SET” or “ESC” to save the setting

▶ Press “▲”, “t1O 00:00” displays on the screen



▶ Press “SET”, hour “00” blinks

▶ Press “▲/▼”, to adjust the hour of start time of the first time

section

▶ Press “SET”, minute “00” blinks

▶ Press “▲/▼”, to adjust the minute of start time of the first time section

▶ Press “SET” or “ESC” to save the setting



▶ Press “▲”, “t1F 00:00” displays on the screen

▶ Press “SET”, hour “00” blinks

▶ Press “▲/▼”, to adjust the hour of close time of the first time section

▶ Press “SET”, minute “00” blinks

▶ Press “▲/▼”, to adjust the minute of close time of the first time section

▶ Press “SET” or “ESC” to save the setting

▶ Press “▲”, to access the second time section setting, same like above steps to set the second, the third time section.

If one of time section needs to be closed, then just set the start time and close time with a same value. (Example: 10:00 start, 10:00 close also)

AH Thermostat function

▶ Select AH submenu, “AH” displays on the screen



▶ Press “SET”, “AH OFF” displays

▶ Press “SET”, “OFF” blinks

▶ Press “▲/▼”, to activate this function, “AH ON” displays

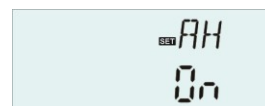

▶ Press “SET” or “ESC” to save the setting

▶ Press “▲”, “AHS S3” displays on the screen

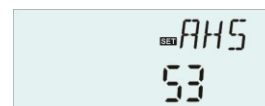

▶ Press “SET”, “S3” blinks

▶ Press “▲/▼”, to select the reference sensor

▶ Press “SET” or “ESC” to save the setting

▶ Press “▲”, “AHO 40°C” displays on the screen

▶ Press “SET”, “40°C” blinks

▶ Press “▲/▼”, to adjust the switch-on temperature

▶ Press “SET” or “ESC” to save the setting

▶ Press “▲”, “AHF 45°C” displays on the screen

▶ Press “SET”, “45°C” blinks

▶ Press “▲/▼”, to adjust the switch-off temperature

▶ Press “SET” or “ESC” to save the setting

▶ Press “▲”, “tA1O 00:00” displays on the screen

▶ Press “SET”, hour “00” blinks

▶ Press “▲/▼”, to adjust the hour of start time of the first time section

▶ Press “SET”, minute “00” blinks

▶ Press “▲/▼”, to adjust the minute of start time of the first time section

▶ Press “SET” or “ESC” to save the setting

▶ Press “▲”, “tA1F 23:59” displays on the screen

▶ Press “SET”, hour “23” blinks

▶ Press “▲/▼”, to adjust the hour of close time of the first time section

▶ Press “SET”, minute “59” blinks

▶ Press “▲/▼”, to adjust the minute of close time of the first time section

▶ Press “SET” or “ESC” to save the setting

▶ Press “▲”, to access the second time section setting, same like above steps to set the second, the third time section.

If you want cease the thermostat function within a time section, then just set its start time and close time with a same value. (Example: 10:00 start, 10:00 close also)

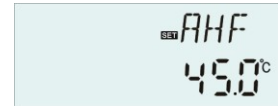
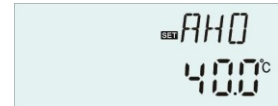

BEEP (Beeper warning function) setting

▶ Press “▲”, select BEEP submenu, “BEEP” displays on the screen



▶ Press “SET”, “BEEP OFF” displays on the screen

▶ Press “SET”, “OFF” blinks

▶ Press “▲/▼”, to activate this function, “BEEP ON” displays on the screen



▶ Press “SET” or “ESC” to save the setting

7.7 MAN Manual operation

For control and service work, the operating mode of the relays can be manually adjusted. For this purpose, select the adjustment menu MAN (for R1, R2, R3, HR) to set output “On/OFF” Manually.

i Note: When manual mode is activated, sign  blinks on the screen, controller runs for 15 minutes and then switch-off all output, control exits manual mode automatically.

Menu structure

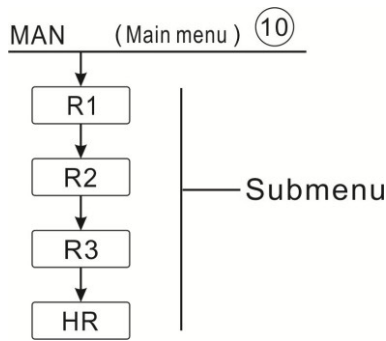

Main Menu	Submenu	Factory set	Adjustable range	Description
MAN				Manual mode
	R1	OFF	ON/OFF	R1 on and off
	R2	OFF	ON/OFF	R2 on and off
	R3	OFF	ON/OFF	R3 on and off
	HR	OFF	ON/OFF	HR on and off

Function setup

- ▶ Press “▲”, “R1” displays on the screen
- ▶ Press “SET”, “R1 OFF” displays
- ▶ Press “SET”, “OFF” blinks
- ▶ Press “▲/▼”, to activate this function, “R1 ON” displays
- ▶ Press “SET” or “ESC” to save the setting
- ▶ Press “▲”, “R2” displays, repeat above steps to set the manual output of R1,R2, R3, HR.

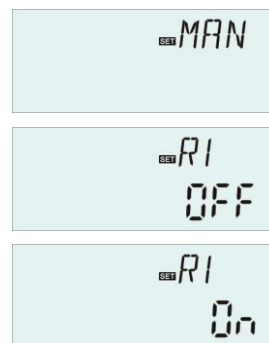

7.8 BLPR Blocking protection

Function description:

In order to protect the pumps against blocking after standstill, the controller is equipped with a blocking protection function. This function switches on the relays one after another every

day at 12:00 a.m and pump runs for 10s at 100 % speed.



Function setting

- ▶ Select main menu BLPR (blocking protection), “BLPR” displays on the screen
- ▶ Press “SET”, “BLPR OFF” displays
- ▶ Press “SET”, “OFF” blinks
- ▶ Press “▲/▼”, to activate this function, “BLPR ON” displays on the screen
- ▶ Press “SET” or “ESC” to save the setting



7.9 OTDI Thermal Disinfection function

Function description:

This function helps to prevent the spread of Legionella in DHW tanks by systematically activating the after-heating.

For thermal disinfection, the temperature at the allocated sensor has to be monitored. During the monitoring period PDIS, this protection ensures the disinfection temperature is continuously exceeded the disinfection temperature TDIS for the entire disinfection period DDIS. Thermal disinfection can only be completed when the disinfection temperature is exceeded for the duration of the disinfection period without any interruption.

The monitoring period PDIS starts as soon as the temperature at the allocated sensor falls below the disinfection temperature TDIS, once the monitoring period PDIS ends, disinfection period SDIS starts, and the allocated reference relay activates the after-heating, when tank temperature exceeds the disinfection temperature, disinfection phase DDIS starts and disinfection heating time countdowns, countdown finishes, disinfection heating finishes.

Menu structure

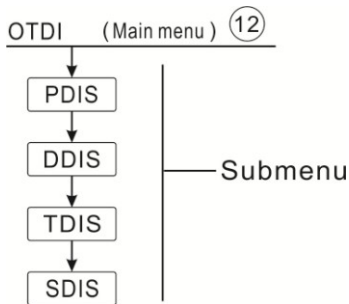

Menu	Submenu	Factory set	Adjustable range	Step per adjust	Description
OTDI		OFF	ON/OFF		Disinfection function
	PDIS	7d	0-30d	1d	Time section of disinfection monitoring
	DDIS	10min	1-180	1min	Heating time of disinfection
	TDIS	70°C	0-90°C	1°C	Temperature of disinfection
	SDIS	18:00	00:00-21:00	1:00	Start time of disinfection

Function setting

- ▶ Press “▲”, “OTDI” displays on the screen
- ▶ Press “SET”, “OTDI OFF” display
- ▶ Press “SET”, “OFF” blinks
- ▶ Press “▲/▼”, to activate this function, “OTDI ON” displays
- ▶ Press “SET” or “ESC” to save the setting
- ▶ Press “▲”, “PDIS 7” displays
- ▶ Press “SET”, “7” blinks
- ▶ Press “▲/▼”, to adjust the days for disinfection monitoring,
- ▶ Press “SET” or “ESC” to save the setting
- ▶ Press “▲”, “DDIS 10Min” displays on the screen
- ▶ Press “SET”, “10” blinks
- ▶ Press “▲/▼”, to adjust the heating time of disinfection
- ▶ Press “SET” or “ESC” to save the setting
- ▶ Press “▲”, “TDIS 70°C” displays on the screen
- ▶ Press “SET”, “70°C” blinks
- ▶ Press “▲/▼”, to adjust the temperature of disinfection
- ▶ Press “SET” or “ESC” to save the setting



- ▶ Press “▲”, “SDIS 18:00” displays on the screen
- ▶ Press “SET”, “18” blinks
- ▶ Press “▲/▼”, to adjust the start time of the disinfection
- ▶ Press “SET” or “ESC” to save the setting

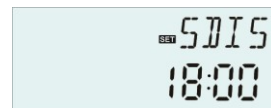

7.10 OHQM Thermal quantity measurement

i Note: Activate the heat measurement function (OHQM) will occupy T4, T5, so the hot water circulation function (CIRC) will deactivate automatically, the two function can't available at the same time, and AH Thermostat function only set object sensor T2 or T3.

The thermal quantity measurement can be carried out in 2 different ways:

1. Fixed flow rate (use flow meter with glass window)
2. With rotary vane flow mater FS

● Thermal quantity measurement with fixed flow rate value

The thermal quantity measurement calculation (estimation) uses the temperature difference between the flow sensor T5 and return sensor T4 and the entered flow rate (at 100 % pump speed).

i Note: sensor of flow for thermal quantity measurement is default set in solar system, it can't be reset.

Under menu FTYP to set the flow rate type to 1

Read the flow rate (l/min) and enter it in the **FMAX** menu

Under menu **MEDT** and **MED%** to set the antifreeze medium type and concentration of the heat transfer fluid

Antifreeze type:

- 0: Water
- 1: Propylene glycol
- 2: Ethylene glycol
- 3: Tyfocol LS / G-LS

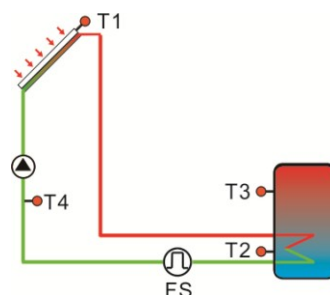

Thermal quantity measurement with rotary vane flow meter (FRT)

Under menu FTYP, set the flow type to 3 (FRT)

The thermal quantity measurement uses the temperature difference between flow sensor T5 and return sensor T4 and the flow rate transmitted by the FRT flow meter.

Under menu **MEDT** and **MED%** to set the antifreeze medium

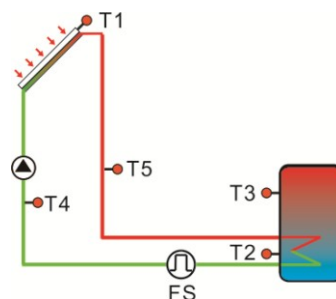

type and concentration of the heat transfer fluid

Menu structure

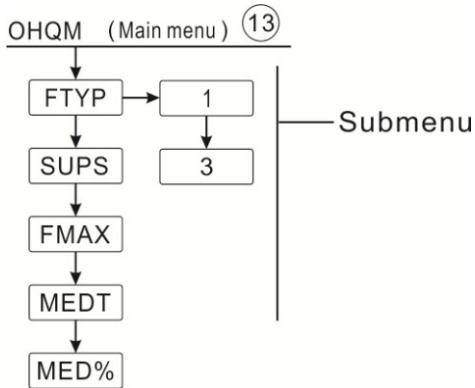

Menu	Submenu 1	Submenu 2	Factory set	Adjustable range	Step per adjust	Description
OHQM			OFF	ON/OFF		Thermal quantity measurement
	FTYP					Flow meter selection
		1	1			Flow meter with fixed flow value
		3				Rotary vane flow meter (FRT)
	SUPS		S5	S1/S5		Flow sensor selection(S5 or S1 can be selected, corresponding to T5 or T1)
	FMAX		6L/min	0.5-100L/min	0.1	Flow rate enter
	MEDT		3	0-3		Medium type 0: water 1: Propylene glycol 2: Ethylene glycol 3: Tyfocol LS/G-LS;
	MED%		45%	20-70%	1%	Concentration of medium

Function setting

- ▶ Select OHQM menu
- ▶ Press “SET”, “OHQM OFF” displays on the screen



- ▶ Press “SET”, “OFF” blinks
- ▶ Press “▲/▼”, to activate this function, “OHQM ON” displays on the screen
- ▶ Press “SET” or “ESC” to save the setting
- ▶ Press “▲”, “FTYP 1” displays
- ▶ Press “SET”, “1” blinks
- ▶ Press “▲/▼”, select type of the flow meter (1, and 3)
- ▶ Press “SET” or “ESC” to save the setting
- ▶ Press “▲”, “SUPS S5” displays on the screen
- ▶ Press “SET”, “S5” blinks
- ▶ Press “▲/▼”, to adjust object sensor (S5 or S1 can be selected, corresponding to T5 or T1)
- ▶ Press “SET” or “ESC” to save the setting
- ▶ Press “▲”, “FMAX 6” displays on the screen
- ▶ Press “SET”, “6” blinks
- ▶ Press “▲/▼”, to adjust flow rate
- ▶ Press “SET” or “ESC” to save the setting
- ▶ Press “▲”, “MEDT 3” displays on the screen
- ▶ Press “SET”, “3” blinks
- ▶ Press “▲/▼”, to select medium type
- ▶ Press “SET” or “ESC” to save the setting
- ▶ Press “▲”, “MED% 45” displays on the screen
- ▶ Press “SET”, “45” blinks
- ▶ Press “▲/▼”, to adjust the concentration of medium
- ▶ Press “SET” or “ESC” to save the setting

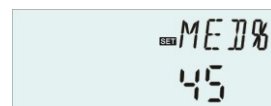



7.11 FS Flow meter selection and flow rate monitoring

Under this menu, it is possible to set the flow meter (FRT) on or off and set its measuring range.

FLOW (flow monitoring)

Function description

Flow monitoring function is designed to detect whether flow exists in the solar system and therefore to switch-off the corresponding pump in case of no flow, it can avoid damaging of the solar system, for example, avoiding pump dry running

If relay R1 is powered, flow rate of flow sensor will be monitored. After a delay detection time (DELY), if no flow rate is detected, error message will appear, and sign   will blinks

on the screen.

If “OFF” option of the flow monitoring function is activated, and then the loaded tank is stopped to be heated until error message is removed, then monitoring function is activated again.

i **Note:** if the selected flow meter is not connected to the controller, sign  will blink on the screen.

Main menu	Submenu 1	Factor y set	Adjustable range	Step per adjust	Description
FS		OFF	OFF/ON		Rotary vane flow meter
	FLOW	ON	ON/OFF		Non flow warning
	DELY	30s	1-600s	1s	Checking time of non flow warning

Function setting

- ▶ Select FS menu
- ▶ Press “SET”, “FS OFF” displays on the screen
- ▶ Press “SET”, “OFF” blinks
- ▶ Press “▲/▼”, to activate this function, “FS ON” displays on the screen
- ▶ Press “▲”, “FLOW ON” displays on the screen
- ▶ Press “SET”, “ON” blinks
- ▶ Press “▲/▼”, to activate this function, “FLOW OFF” displays
- ▶ Press “▲”, “DELY 30” displays on the screen
- ▶ Press “SET”, “30” blinks
- ▶ Press “▲/▼”, to adjust the checking time of non-flow warning
- ▶ Press “SET” or “ESC” to save the setting
- ▶ Press “ESC”, to return previous menu



7.12 UNIT C-F Switch

Under this menu, unit of temperature can be switched between °C degree celsius and

Fahrenheit.



Function setting

- ▶ Select UNIT menu
- ▶ Press “SET”, “TEMP °C” displays on the screen
- ▶ Press “SET”, “°C” blinks
- ▶ Press “▲/▼”, to select temperature unit
- ▶ Press “SET” or “ESC” to save the setting



7.13 RET Reset

By means of the reset function, all adjustments can be reset to the factory settings.

RSTP (Menu parameters): through reset function, all parameters can be reset to factory setting

CHQM (accumulated thermal quantity): accumulated thermal quantity can be reset to 0

CPT (accumulated running time of pump): accumulated solar pump running time (R1 time/R2 time) can be reset to 0

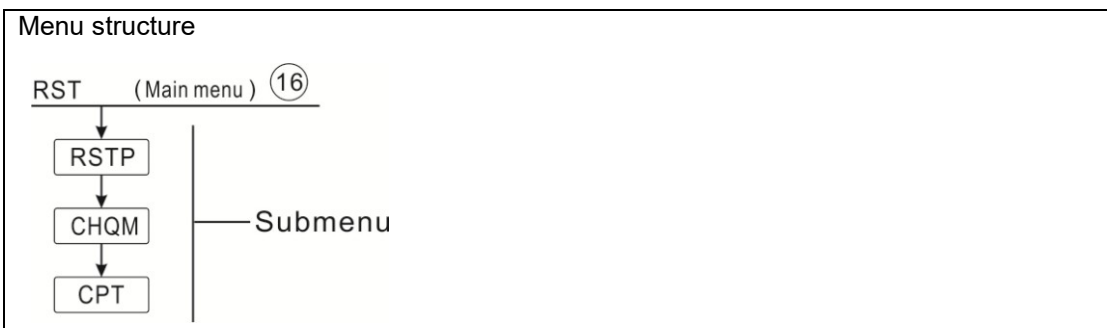

Function setting

- ▶ Select RST menu
- ▶ Press “SET”, “RSTP” displays on the screen
- ▶ Press “SET”, “YES” blinks
- ▶ Press “SET” for 3 seconds, beeper sounds “di” 3 times, “YES”



lighting, and it indicates system is recovered to factory set.

▶ Press “ESC” return to the submenu

▶ Press “▲”, “CHQM” displays, repeat above steps to reset the CHQM, CPT parameters.

7.14 PASS Password setup

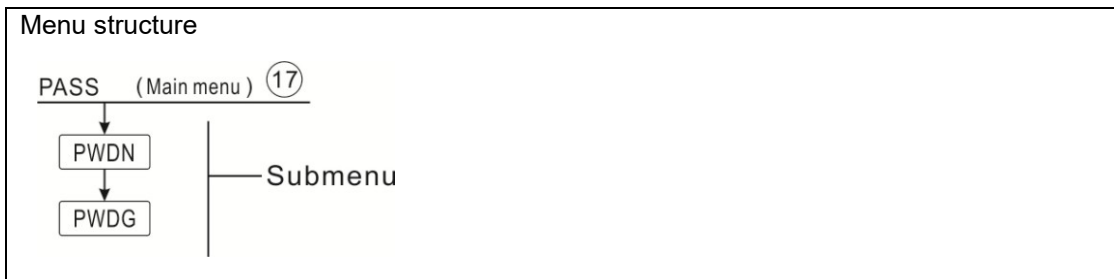

Function Setting

Select the password setting, “PASS” menu

▶ Press “SET” button, “PWDN 0000” displays on the screen, to enter the new password

▶ Press “SET” button again, the first digital blinks

▶ Press “▲/▼”, to enter the correct digital, repeats same process to enter the second, the third and the fourth digital.

▶ Press “SET” button, “PWDG 0000” displays on the screen, to enter the new password again, after confirm the new password, “OK”

displays on the screen, it indicates the new password setting successfully.



i Note: If the password is forgot, it is impossible to recover, but you can recover the password to the factory set, then you can reedit a password like above described steps, doing like following to recover to factory set.

▶ Switch-off the power to controller

▶ Hold down “ESC” button

▶ Reconnect the power supply, when beeper sounds 3 di....., and then release “ESC” button, Controller recovers to the factory set password (factory set password is 0000)

7.15 M.H Manual heating

Function Description:

It is possible to trigger back-up heating manually with this controller to heat tank. When tank temperature is lower than the set point of the switch-on temperature, manual heating function is in standby, when you press the manual heating button, heating will start, and it works until

tank temperature reaches to the set point.

Activate/deactivate this function:

- ▶ Press “M.H” button, temperature “60°C” blinks on the screen
- ▶ Press “▲/▼”, to adjust the desired temperature, adjustable range 10°C~80°C, factory set is 60°C
- ▶ Press “M.H” or “ESC” or waiting for 20 seconds to trigger the manual heating, then manual sign (hand) lighted on the screen, and the heating sign (wavy lines) blinks the screen
- ▶ Press “M.H” again, switch-off manual heating.

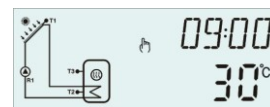

i Note: Manual heating is not a continuous heating process, it is triggered manually, and when the temperature reaches to the set point, the heating process is stopped. And manual heating function is stopped automatically.



7.16 Holiday function

The holiday function is used for operating the system when no water consumption is expected, e. g. during a holiday absence. This function cools down the system in order to reduce the thermal load.

2 cooling functions are available: tank cooling (OSTC) and tank heat transfer (OHDP).

i Note: Controller is designed to run tank heat transfer (OHDP) function priority, when tank heat transfer (OHDP) function is deactivated, then tank cooling function (OHTC) runs automatically in turn.

Activate/deactivate this function:

- ▶ Press “” button for 3 seconds, “HDAY 05” displays on the screen
- ▶ Press “▲/▼”, to adjust holiday’s days, adjustable range 0-99 days
- ▶ Press “” again, holiday function is closed, sign “” closed.

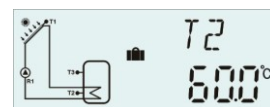
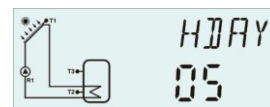

i Note: When you return from holiday, please deactivate this function in time.

7.17 Economic model

Function Description:

In the economic mode, the timed heating function is invalid, and the water tank can only be heated by manual heating (M.H) to start the electric heating.

Turn on/off the function:

▶ Press and hold the "▼" key for 3 seconds,  the icon will be displayed, the function will turn on

▶ Press and hold the "▼" key for 3 seconds,  the icon will be disappear, and the function will turn off

7.18 Shortcut key function

1. After the flow fault alarm, press the "▲/▼" key to query the flow display interface (L/M 00). Press and hold "SET" for 3 seconds to immediately turn off no flow alarm function (FLOW).
2. Press and hold "ESC" for 3 seconds to start the circuit pump (R1) manually.
3. Press and hold "SET" for 3 seconds to view the type of circuit pump (R1).

8. Protection function

8.1 Memory function during power failure

When power of controller is failed, and when power is switched-on again, controller will keep the parameters which set before power failure.

8.2 Screen protection

When no any press on button for 5 minutes, screen protection is activated automatically, and then LED background lamp is switched-off. Through press any button to light LED lamp again.

8.3 Trouble checking

The built-in controller is a qualified product, which is conceived for years of continuous trouble-free operation. If a problem occurs, the most of causes is from the peripheral components but no relation with controller itself. The following description of some well-known problems should help the installer and operator to isolate the problem, so that the system can be put into operation as quickly as possible and to avoid unnecessary cost. Of course, not all possible problems can be listed here. However, most of the normal problems encountered with the controller can be found in the list below, only return the controller to seller when you are absolutely sure that none of the problems listed below is responsible for the fault.

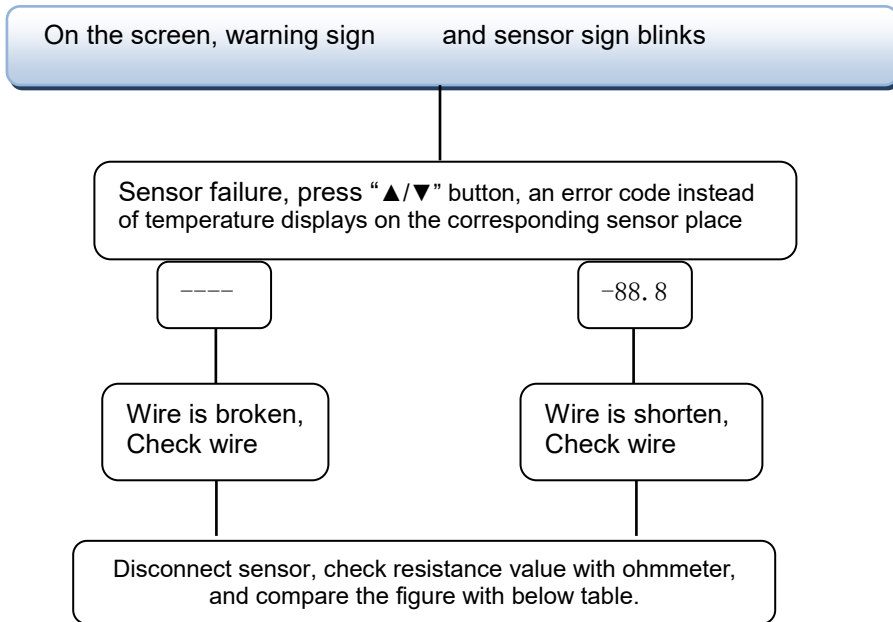

PT1000 resistance value

℃	0	10	20	30	40	50	60	70	80	90	100	110	120
Ω	1000	1039	1077	1116	1155	1194	1232	1270	1309	1347	1385	1422	1460

NTC 10K B=3950 resistance value



℃	0	10	20	30	40	50	60	70	80	90	100	110	120
Ω	33620	20174	12535	8037	5301	3588	2486	1759	1270	933	697	529	407

9. Quality Guarantee

Manufacturer provides following quality responsibilities to end-users: within the period of quality responsibilities, manufacturer will exclude the failure caused by production and material selection. A correct installation will not lead to failure. When a user takes incorrect handling way, incorrect installation, improper or crude handling, and wrong connection of Warm water outflow upwards.

The quality warranty expires within 18 months after the date of purchasing the controller.

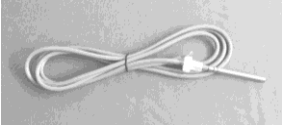
10. Accessories

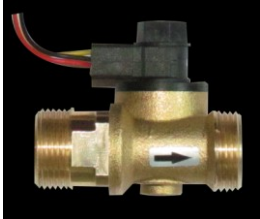
Products name	Specification	Products picture
A01: High accurate Pt1000 sensor for collector	PT1000, $\Phi 6 \times 50\text{mm}$	
A02: High accurate sensor for tank and pipe	NTC10K, B=3950, $\Phi 6 \times 50\text{mm}$	
A05: 304 stainless steel thermo well	304 stainless steel with thread 1/2' OT, Size: $\Phi 8 \times 200$	
A17:FRT digital flow meter	Parameter: male thread 3/4 Power: 5-24V/DC	
SR802 Unit for high power electrical heater	Dimension: $100\text{mm} \times 100\text{mm} \times 65\text{mm}$ Power supply: AC180V ~ 264V, 50/60Hz Suitable power: $\leq 4000\text{W}$ Available ambient temperature: $-10 \sim 50^\circ\text{C}$ Waterproof grade: IP43	